

UNIVERSAL JOINTS

MOLDED TYPE

**JPE SERIES
WITH SLIDE EXTENSION**



MOLDED DELRIN BODY provides vibration dampening and electrical insulation.

MAX. ANGULAR DISPLACEMENT—90°

MAX. AMBIENT TEMPERATURE—180°F

MAX. EXTENSION—3/4"

COMPLETE WITH SETSCREWS

STANDARD TOLERANCES

DIMENSION	TOLERANCE	
BORE	All	+.001 –.000

REFERENCE PAGES

Mounting—148

MATERIALS

Delrin Body
Nickel Plated Brass Spider and Insert

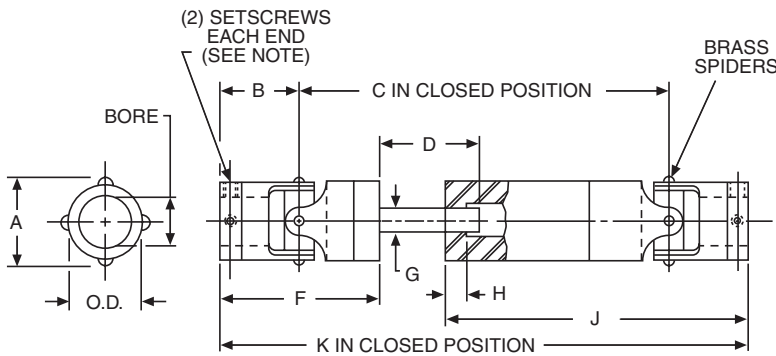

ALL DIMENSIONS IN INCHES
ORDER BY CATALOG NUMBER OR ITEM CODE

Bore	Bore Depth (Typical)	O.D.	A	B	C	D	E	F	G (Sq.)	H	J	K	Setscrew	Catalog Number	Item Code
1/8	.52	3/8	.41	.74	2-59/64	1-1/8	—	1-47/64	3/16	23/64	2-43/64	4-13/32	#4-40	JPE37-1/8	54210
3/16	.63	1/2	.54	.91	2-23/64	1-1/8	3/8	1-34/64	3/16	23/64	2-9/16	4-11/64	#6-32	JPE37-3/16	54211
3/16	.63	1/2	.54	.91	2-23/64	1-1/8	3/8	1-34/64	3/16	23/64	2-9/16	4-11/64	#6-32	JPE50-3/16	54212
1/4	.63	1/2	.54	.91	2-23/64	1-1/8	3/8	1-34/64	3/16	23/64	2-9/16	4-11/64	#6-32	JPE50-1/4	54213

LOAD DATA

Basic Size	Maximum Recommended Torque (Lb. Ins.)*	
	Closed	Open
JPE37	8	5
JPE50	14	10

*This is the ultimate or breaking torque for static zero angle conditions. Actual operating conditions will dictate use of significantly lower values.